

# CHF511TOP



## Electric combi oven with touch screen 5 trays 1/1 GN

Who said that you always have to give something up in small kitchens? With CHF 511 TOP you can have everything you've always wanted in the kitchen, and maybe a lot more: 500 storable recipes, the possibility of choosing between traditional cooking and direct steam and an elegant and easy-to-use display.

MILLENNIAL's innovation at the service of professionals who does not compromise, ever.

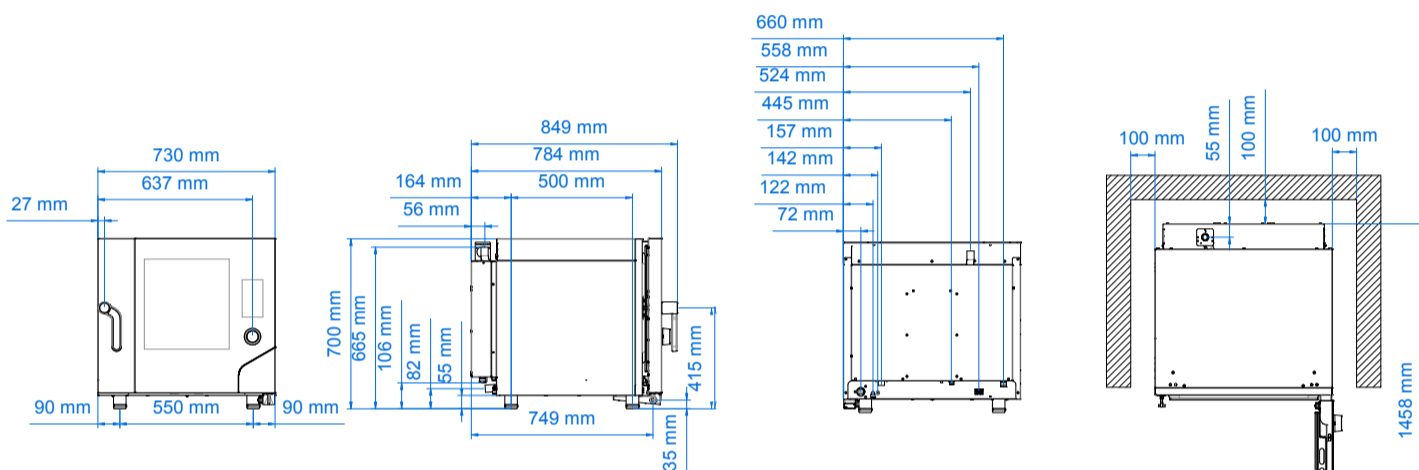

### Dimensional features

Dimensions (WxDxH mm)	730 x 849 x 700
Weight (kg)	76
Distance between rack rails (mm)	68

### Electrical features

Power supply (kW)	7,8
Frequency (Hz)	50/60
Voltage (V)	AC 380/400 3N
N° motors	1 bidirectional
Boiler (kW)	/
Protection against water	IPX5

### Plus

Patented fan guard system <b>Airflowlogic™</b>
Patented system for direct steam <b>Humilogic™</b>
Patented system for cooking chamber drying <b>Drylogic™</b>
Voltage (V) : AC 220/230 3
Available on request at the order Voltage (V) : AC 220/230
Left side opening door
Humidity management software
Wi-Fi communication system
Knob for quick selection of the touch screen
Programmable oven start
N ° 40 recipes stored
Control panel in 40 languages: Arabic, Armenian, Azerbaijani, Bahasa (Indonesia), Bahasa (Malaysia), Bosnian, Bulgarian, Czech, Chinese, South Korean, Croatian, Danish, Philippine, Finnish, French, Georgian, Japanese, Greek, English, Icelandic, Italian, Kazakh, Lithuanian, Norwegian, Dutch, Persian (Iran), Polish, Portuguese, Romanian, Russian, Serbian, Slovenian, Spanish, Swedish, German, Thai, Turkish, Ukrainian, Hungarian, Vietnamese
HACCP system
Adjustable door hinges

### Functional features

Power	Electricity
Capacity	N° 5 trays/grids 1/1 GN
Type of cooking	Semistatic + ventilated
Steam	Direct steam controlled by touch screen (10 levels )
Cooking chamber	AISI 304 stainless steel
Temperature	30 - 270 °C
Temperature control	Digital probe thermometer
Control panel	Touch screen
N° programs	500
Programmable cooking steps	10
Pre-heating temperature	180 °C
Pre-heating function	Programmable
Door	Right side opening Ventilated Inspectionable glass
Modularity	Yes
Feet	Adjustable

### Equipment

Cardboard box dimensions with pallet (WxDxH mm)	790 x 905 x 865 mm
Lateral supports	1 right + 1 left
Cable	Three-phase+neutral [5G,2,5]-L=1600 mm
USB port	
Multipoint core probe cod. CHSC3P	
Plug for "vacuum cooking" probe cod. CHSC-SV	
Automatic washing system integrated	
Condensate collection bowl, with drain on door	
Hinge with door locking for openings adjusted at 60°, 90°, 120°, 180°	